

Ref. **3019**

MACHO ÚNICO MANO BSPT (RC)

BSPT (RC) Hand Single Tap
Taraud à Main BSPT (RC)



Rosca británica para tubo cónica
British Standard Pipe Taper
Raccord BSPT

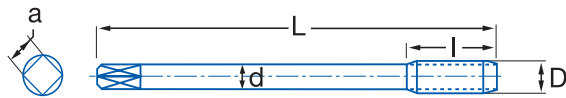

HSS	DIN 5157	C 2-3h		α $10^\circ \pm 2$	N°3 Acabado Finishing Finition
-----	----------	--------	--	------------------------------	--------------------------------------

Grupo 1 Subgr. 1.1	Grupo 5 Subgr. 5.1	Grupo 3 Subgr. 3.1/3.2	Grupo 6 Subgr. 6.1/6.2/6.3
-----------------------	-----------------------	---------------------------	-------------------------------

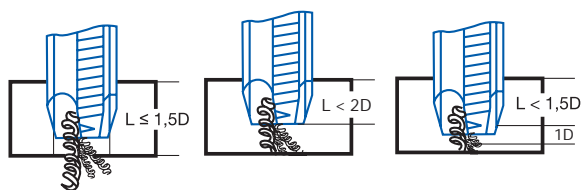

BSPT	Hilos Threads	Filets	L mm	l mm	d mm	a mm	Z	N° Art. HSS	€
B1/8	28		65	19	7	5,50	3	38254	22,13
B1/4	19		70	25	11	9,00	4	38255	31,20
B3/8	19		75	25	12	9,00	5	38256	43,32
B1/2	14		80	31	16	12,00	5	38257	60,65
B5/8	14		80	36	18	14,00	5	38258	110,99
B3/4	14		85	33	20	17,00	5	76138	102,93
B7/8	14		100	36	22	17,00	6	38259	184,98
B1"	11		110	38	25	21,50	6	38260	156,70

Ref. **3025**

JUEGO MACHOS MANO UNEF

UNEF Hand Tap Set

Jeu de Tarauds à Main UNEF

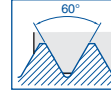

Rosca americana unificada cilíndrica
Unified Thread Standard
Filetage unifié

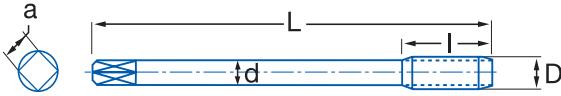

HSS	DIN 2181	C 2-3h	Tol. 2B		α $10^\circ \pm 2$		N°1 Desbaste Roughing Ebauche	N°3 Acabado Finishing Finition
Grupo 1 Subgr. 1.1	Grupo 5 Subgr. 5.1	Grupo 3 Subgr. 3.1/3.2	Grupo 6 Subgr. 6.1/6.2/6.3					

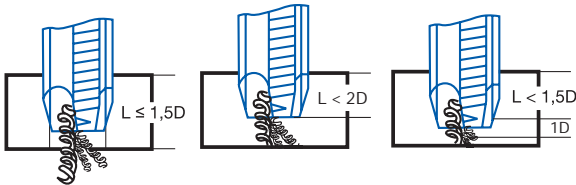

UNEF	Hilos Threads	Filets	L mm	l mm	d mm	a mm	Z	N° Art. HSS	€
UNEF 1/4	32		50	18	6	4,90	3	38269	69,72
UNEF 5/16	32		56	22	6	4,90	3	75857	77,89
UNEF 3/8	32		63	22	7	5,50	3	75863	89,11
UNEF 7/16	28		63	22	8	6,20	4	38270	113,43
UNEF 1/2	28		75	24	9	7,00	4	75876	128,18
UNEF 9/16	24		80	28	11	9,00	4	16853	149,95
UNEF 5/8	24		80	28	12	9,00	4	38271	208,70
UNEF 3/4	20		95	32	14	11,00	4	38272	309,05
UNEF 1"	20		110	40	18	14,50	4	38273	442,21

Ref. **3011**

MACHO ÚNICO MANO PG

PG Hand Single Tap

Taraud à Main PG

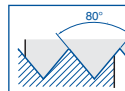

Rosca para tubos eléctricos en acero
Steel Electric Pipe Thread
Filetage tubes électriques en acier

HSS	DIN 40432	C 2-3h		α $10^\circ \pm 2$	Nº3 Acabado Finishing Finition
-----	-----------	--------	--	------------------------------	--------------------------------------

Grupo 1 Subgr. 1.1	Grupo 5 Subgr. 5.1	Grupo 3 Subgr. 3.1/3.2	Grupo 6 Subgr. 6.1/6.2/6.3
-----------------------	-----------------------	---------------------------	-------------------------------

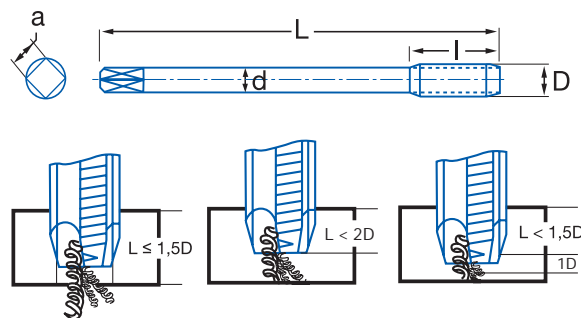

PG	D mm	Hilos Threads	Filets Filets	L mm	l mm	d mm	a mm	Z	Nº Art. HSS	€
PG 07	12,50	20		70	22	9	7,00	4	38291	23,28
PG 09	15,20	18		70	22	12	9,00	4	38292	29,58
PG 11	18,60	18		80	22	14	11,00	4	38293	41,09
PG 13,5	20,40	18		80	22	16	12,00	4	38294	45,06
PG 16	22,50	18		80	22	18	14,50	4	38295	54,10
PG 21	28,30	16		90	22	22	18,00	5	38296	79,57
PG 29	37,00	16		100	25	28	22,00	5	38297	157,97
PG 36	47,00	16		140	40	36	29,00	6	38298	263,88
PG 42	54,00	16		140	40	40	32,00	8	38299	313,38
PG 48	59,30	16		160	40	45	35,00	8	38300	395,20